

Backdraft Damper • 4" Deep • Single Thickness Blades • Extruded Aluminum • -40°F to 190°F Temperature

Standard Construction and Materials

FRAME: .081" and .125" thick (nominal) 6063-T52/T6 extruded aluminum alloy. 1" x 4" x 1" channel frame on all sides.

BLADES: .081" thick (nominal) 6063-T52/T6 extruded aluminum alloy, designed for strength and low leakage with overlapping edges.

AXELS: 1/2" dia. extruded aluminum pin-lock design.

BLADE SEALS: Silicone rubber off-set leg at blade edges. None at jams.

BEARINGS: Celcon bearing material so that there will be no metal to metal friction.

LINKAGE: Face mounted in the airstream.

FINISH: Mill standard, optional finishes available.

TEMP. LIMITS: -40°F to +190°F

Options

- Aluminum (1 5/8" x 6" x 1 1/4") Frame
- Flanged (2" x 4" x 5/8") Frame
- Steel (Channel or Flange) Frame
- Variety of Bird or Insect Screens
- Linkage Out of Airstream
- Polyurethane or Neoprene Jamb Seals
- Oilite Bronze or Ball Bearings
- Counterweights - adjustable for infinite opening pressures in optional locations. Specify if airstream is horizontal, vertical up or down. Specify to assist or resist opening. Specify locations internally (on blades) or externally (on external shaft).

Notes

1. 1/4" nominal deduction will be made to the opening size given. Dampers are measured by outside dimension.
2. When a non-symmetrical frame cross section is specified (example: flange frame) specify the flange/airflow orientation.
3. Approximate damper weight is 6 1/2 lbs/sq.ft.

Damper Sizes

Min Panel	Max Single Panel
8"W x 8"H	48"W x 72"H

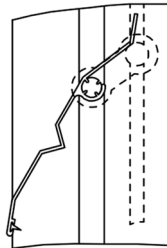

Optional Jamb Linkage and Jamb Seals

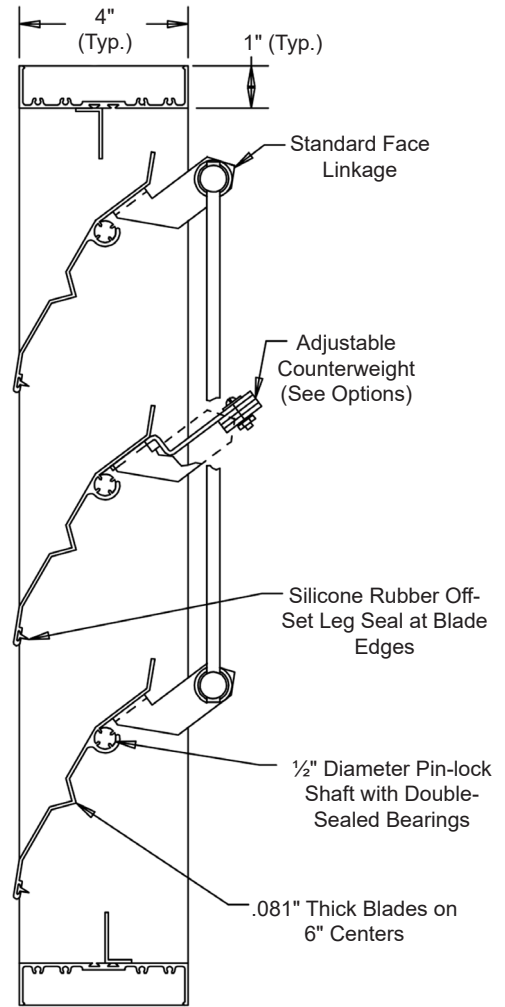

Not to scale.

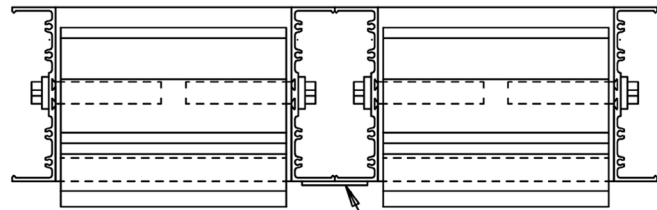

Mullion typ.

Top View

Item #	Qty	Width	Height	Width	Height	Mullion	Counter Balance	Air Flow (Direction)	Union Made
		Opening Size		Damper Size					
Arch. / Eng.:						EDR:	ECN:	Job:	
Contractor:									
Project:						Date:	DWN:	DWG:	

In the interest of product development, Cesco Products reserves the right to make changes without notice.



450 Riverside Dr • Wyalusing PA, 18853
 Phone: 570-746-1888 • Fax: 570-746-9286
 www.cescoproducts.com



Backdraft Damper • 4" Deep • Single Thickness Blades • Extruded Aluminum • -40°F to 190°F Temperature

Pressure Drop Data

Typical performance for model BA55 Backdraft Damper. Size tested 42"W x 42"H, furnished with counterweight to assist opening.

Velocity vs. Pressure Drop

Without Ductwork

Damper installed per AMCA 500 Fig. 5.4 (Face Mounted to a Plenum). Pressure is corrected to .075 lb./cu.ft. air density.

Operational Pressures
Start to Open - .01 in.wg
Fully Open - .52 in.wg

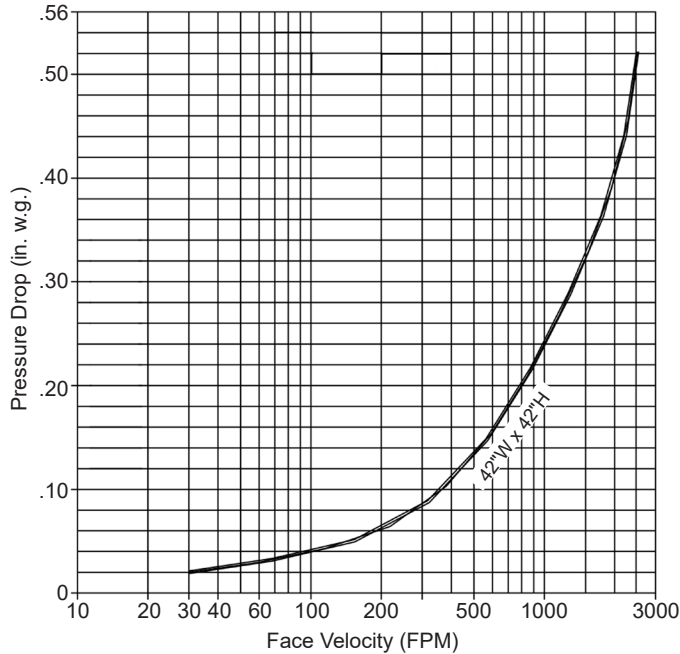

With Ductwork

Damper installed per AMCA 500 Fig. 5.3 (Ductwork installed upstream and downstream of damper). Pressure is corrected to .075 lb./cu.ft. air density.

Operational Pressures
Start to Open - .01 in.wg
Fully Open - .18 in.wg

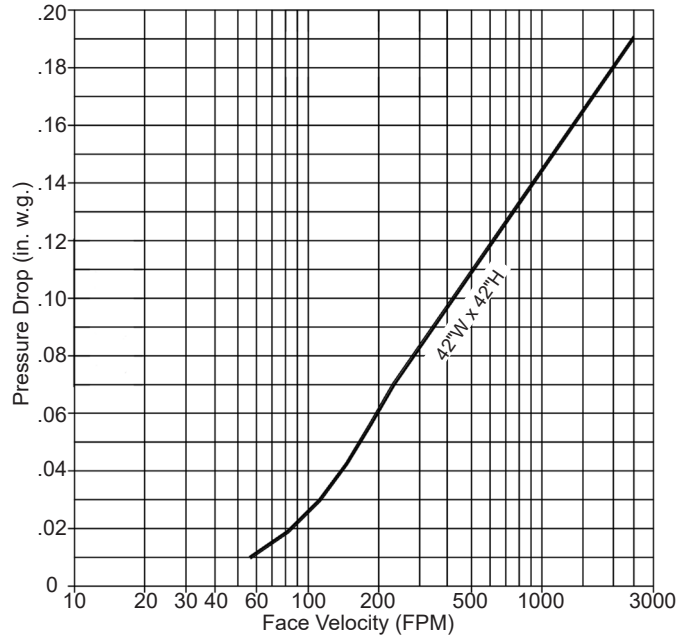

Air Leakage Data

Air leakage quantities shown in the chart are results of tests per AMCA standard 500 and are shown at 0.10 in. w.g. differential pressure and corrected to .075 lb./cu.ft. air density.

Total CFM Air Leakage at .10" Static Pressure Differential Through Closed Damper

Height (in.)	Width (in.)						
	12"	18"	24"	30"	36"	42"	48"
12"	3.0	4.5	6.0	7.5	9.0	10.5	12.0
24"	6.0	9.0	12.0	15.0	18.0	21.0	24.0
36"	9.0	13.5	18.0	22.5	27.0	31.5	36.0
48"	12.0	18.0	24.0	30.0	36.0	42.0	48.0
60"	15.0	22.5	30.0	37.5	45.0	52.5	60.0
72"	18.0	27.0	36.0	45.0	54.0	63.0	72.0

For determining leakage values greater than .10 in.wg to a maximum 4 in.wg use the multiplier correction chart below.

Static Pressure (in)	.2	.3	.4	.5	1.0	2.0	3.0	4.0
Multiplier Correction Factor	1.7	2.0	2.3	2.7	4.0	5.0	6.7	8.3

Air leakage ratings are based on AMCA standard 500 using test set up Fig. 5.4 with damper in the closed position without the aid of a counterweight or other mechanical means to provide closing torque. For a size 42"W x 42"H damper with blade and jamb seals.